

1. MATES WITH APPROPRIATE UNIVERSAL MATE-N-LOK™ PLUG.
2. RECOMMENDED PANEL THICKNESS 0.76 - 2.29.
3. PANEL MUST BE PUNCHED SO THAT THE HOUSING ENTERS THE PANEL IN THE SAME DIRECTION AS THE PUNCH.
4. OPTIONAL FOR KEYING HOUSING IN PANEL.
5. CIRCUIT NUMBER 1 LOCATION.
6. DIMENSION INDICATED IS AS MOLDED. ADDITIONAL GROWTH DUE TO SUBSEQUENT MOISTURE ABSORPTION MAY OCCUR.
7. FOUR RIBS EQUALLY SPACED, NO SPECIFIC ORIENTATION. NO RIBS OR SIX RIBS EQUALLY SPACED, NO SPECIFIC ORIENTATION, OPTIONAL.
8. FOR FOREIGN PRODUCTION ONLY.
9. UNDERWRITERS RECOGNIZED COMPONENT LOGO AND CSA CERTIFICATION LOGO TO BE LOCATED ONCE EACH ON SIDE OF HOUSING.

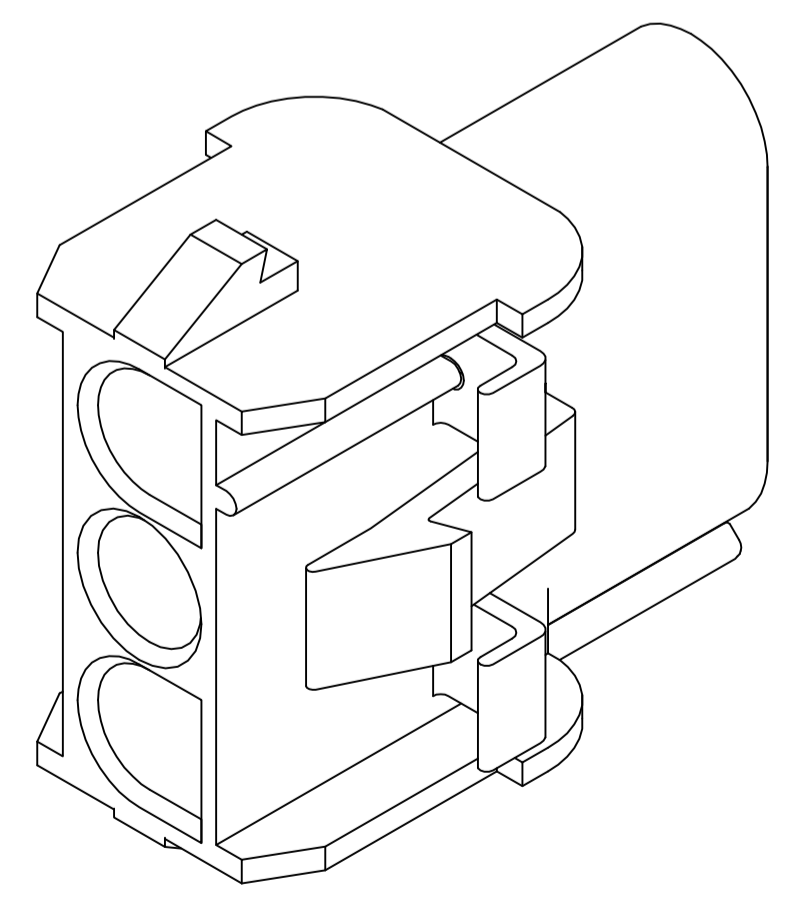
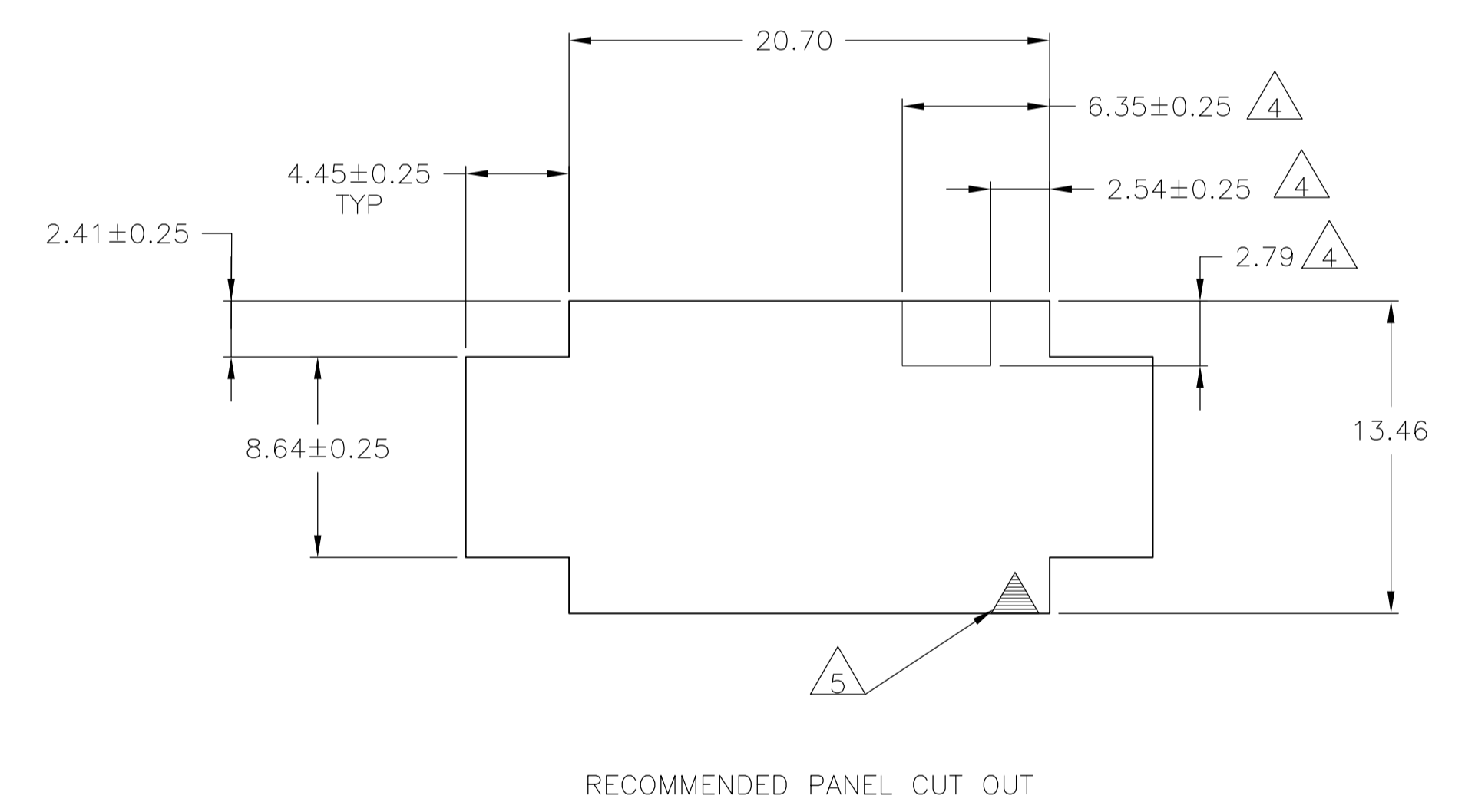
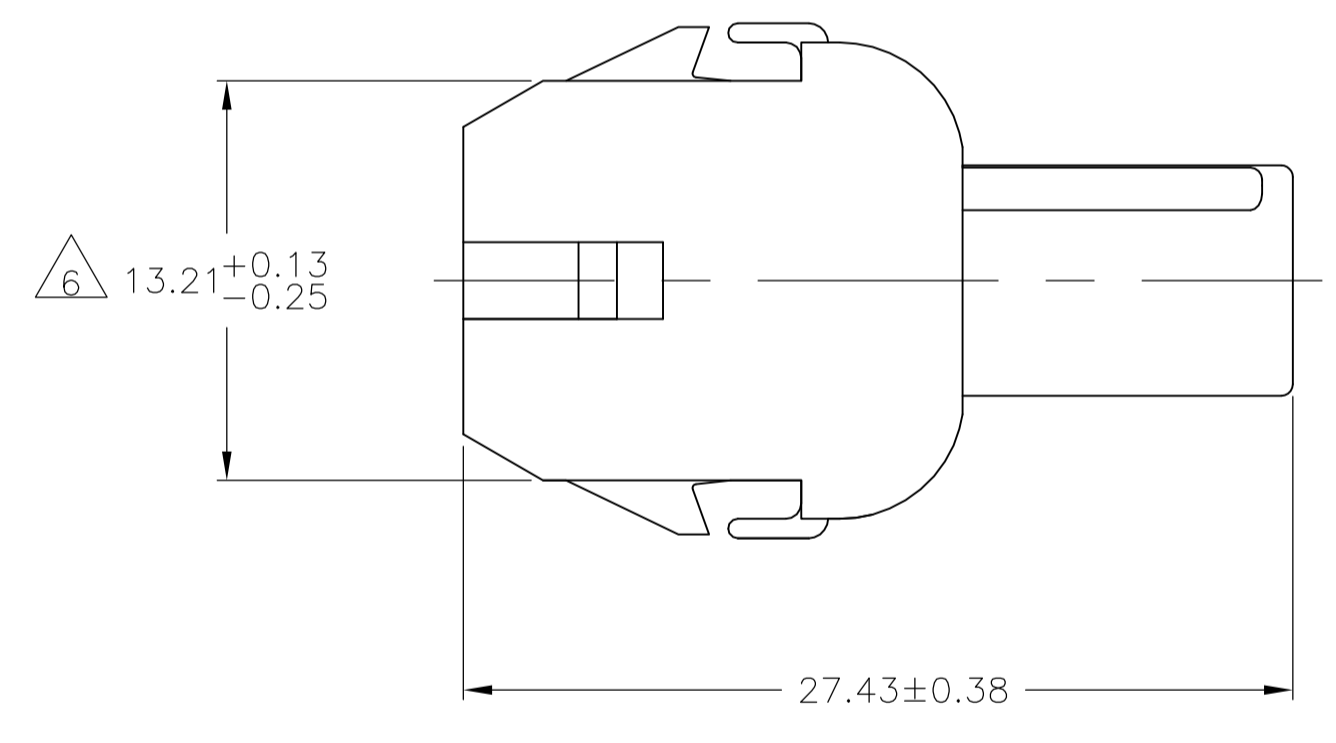
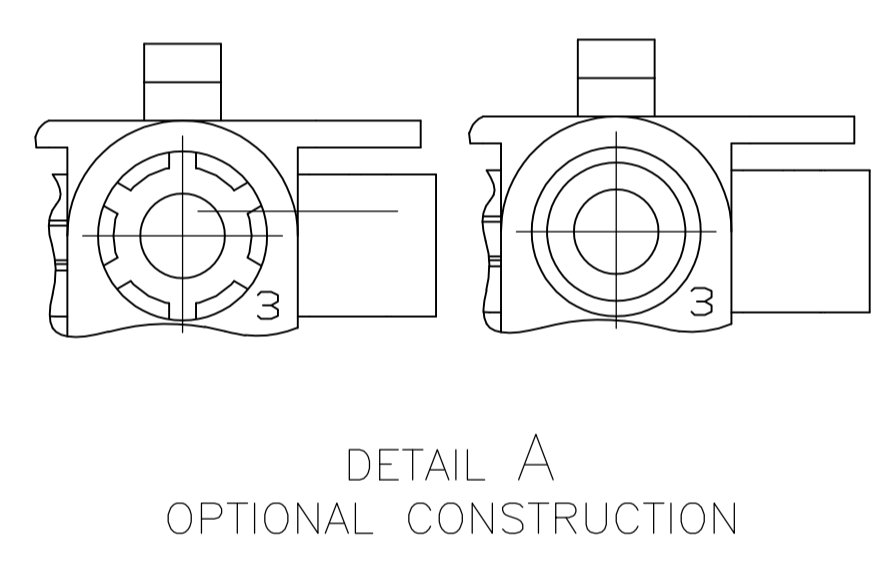

4.45	.175	27.43	1.080
2.79	.110	20.70	.815
2.54	.100	20.32	.800
2.41	.095	13.46	.530
2.29	.090	13.21	.520
0.76	.030	8.64	.340
0.38	.015	8.13	.320
0.25	.010	7.62	.300
0.13	.005	6.35	.250
MM	IN	MM	IN

CONVERSION TABLE

BLACK	NYLON UL94V-0	1-350767-9
GRAY	NYLON UL94V-0	1-350767-8
BLUE	NYLON UL94V-0	1-350767-6
GREEN	NYLON UL94V-0	1-350767-5
YELLOW	NYLON UL94V-0	1-350767-4
ORANGE	NYLON UL94V-0	1-350767-3
RED	NYLON UL94V-0	1-350767-2
BROWN	NYLON UL94V-0	1-350767-1
Δ	NYLON UL94V-0	350767-2
NATURAL	NYLON UL94V-0	350767-1
COLOR	MATERIAL	PART NUMBER

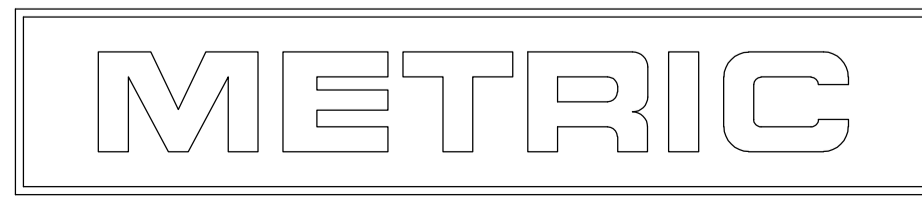

THIS DRAWING IS A CONTROLLED DOCUMENT.

DIMENSIONS: mm	TOLERANCES UNLESS OTHERWISE SPECIFIED:	DIN K. WHITAKER 20JUL92	CHK R. SWING 20JUL92	APVD D. SELF 21JUL92	NAME
0. PLC ± -	1. PLC ± -	2. PLC ± 0.13	3. PLC ± -	4. PLC ± -	ANGLES ± 1°
MATERIAL SEE TABLE	FINISH -	WEIGHT -	SIZE A1	CAGE CODE 00779	DRAWING NO. 350767
CUSTOMER DRAWING		SCALE 4:1	SHEET 1 OF 1	REV Y3	RESTRICTED TO

STE TE Connectivity

CAP.3 CIRCUIT, UNIVERSAL MATE-N-LOK™